

Results of geotechnical modelling of the influence of construction of the deep foundation ditch on the existing historical building

A.B. Ponomaryov ⁱ⁾, S.V. Kaloshina ⁱⁱ⁾, A.V. Zakharov ⁱⁱⁱ⁾, M.A. Bezgodov ^{iv)}, R.I. Shenkman ^{v)} and D.G. Zolotozubov ^{vi)}

i) Professor, Department of Building Production and Geotechnics, Perm National Research Polytechnic University (PNRPU), Komsomol pr., Perm, Russian Federation

ii) Candidate of Technical Sciences, Department of Building Production and Geotechnics, PNRPU, Komsomol pr., Perm, RF

iii) Candidate of Technical Sciences, Department of Building Production and Geotechnics, PNRPU, Komsomol pr., Perm, RF

iv) Ph.D Student, Department of Building Production and Geotechnics, PNRPU, RF

v) Ph.D Student, Department of Building Production and Geotechnics, PNRPU, Komsomol pr., Perm, RF

vi) Candidate of Technical Sciences, Department of Building Production and Geotechnics, PNRPU, Komsomol pr., Perm, RF

ABSTRACT

This document provides information about experience and results of geotechnical modelling of the influence of reconstruction of the building of Perm Opera Theater which includes large extension of existing building with extensive underground part. These work is complicated by different problems like close location to existing buildings with historical value, need for using of underground space during the reconstruction, presence of the soft soils at the base of the existing building and high water table. Paper presents information about engineering solutions which enabled the successful fit into the strict requirements for additional settlements of historic buildings. Also paper presents conclusions which are made on basis of experience of this numerical modeling.

Keywords: deep foundation ditch, soft soils, historical buildings, numerical modelling

1. INTRODUCTION

Reconstruction of buildings in dense urban areas is often associated with the task of ensuring safety of existing buildings and structures. Especially in those cases where there is a significant increase of the volume of the reconstructed building, especially with use of underground space *Kaloshina (2007, 2013)*. The task can be complicated by unstable geological and hydrological conditions on the construction site *Ponomaryov (2006)*. Emerging issues are similar to the construction of new buildings in dense urban areas in many respects, but there is one more problem - maintenance of safety of the reconstructed building. The work became even more complicated when the existing buildings have historical and cultural value. This article presents information about the case of the combination of these complicating factors, which we had to face during the design of reconstruction of building of Perm Opera Theater, Perm region, Russia.

2 GENERAL INFORMATION ABOUT THE DESIGNING OBJECT

The opera house was built in Perm city in 1878 and during the years was rebuilt several times. Existing building is rectangular in plan with dimensions 66.72 x

40.17 m. The building has a variable floor of – four-five floors with a ground floor and basement. The structural layout of the building - mixed framework with longitudinal and transverse load-bearing walls, brick and steel columns.

View of the building in its original form is shown in Figure 1.



Fig. 1. View of the building in its original form

Current appearance of the Perm Opera theater building shown in Figure 2.



Fig. 2. Current appearance of the Perm Opera theater building.

Current reconstruction of the existing building includes large extension of existing building with extensive underground part is in designing progress now. The scheme of the existing building with designing reconstruction part of the theater is shown in Figure 3.

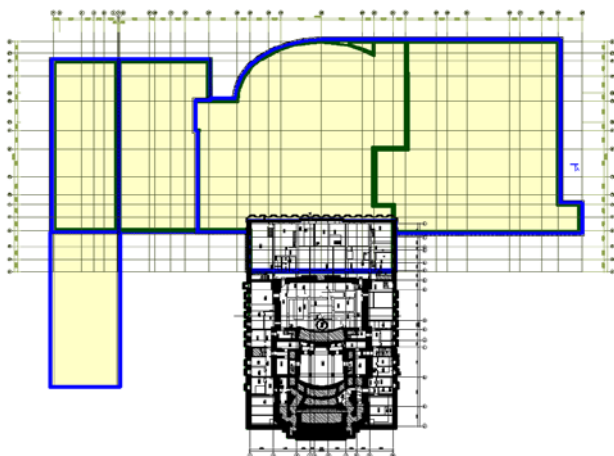

Fig. 3. The scheme of the existing building with the reconstruction part of the theater

Sectional view of the existing theater building with additional part shown in Figure 4.

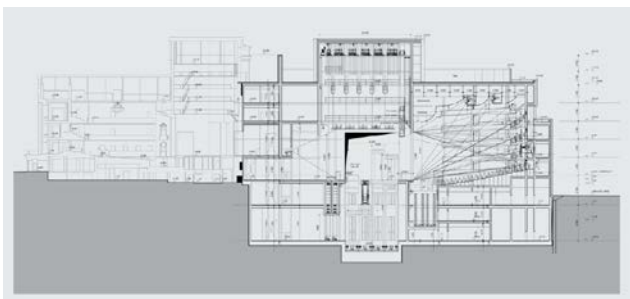

Fig. 4. Sectional view of the existing theater building with additional part

Execution of these works is complicated by the fact that the building is located in historic downtown. The construction site is surrounded by a huge number of

roads, utility networks and other historic buildings. Some of them are in poor technical condition. Scheme of the construction site is shown in Figure 5.



Fig. 5. Scheme of the construction site

A general view of the surrounding historical buildings is shown in Figure 6



Fig. 6. A general view of the surrounding historical buildings

Also the construction site is not related to favorable from a geological point of view. From the surface to a depth of 3 meters bulk soil is located then to a depth 18-20 m there are water-saturated light loam with a modulus of deformation varies in the range of 1.5-5 MPa (according to the results of numerous stamp tests) which are underlined by sandstones. The construction site belongs to the flooded areas with depth of the groundwater level less than 2 m at certain times of the year. This geological conditions are a significant complicating factor for underground construction *Ponomaryov (2013)*.

In the geological structure of the construction site, according to the drilling and static probing, to 50 m

depth, participate Permian rocks (sandstones, claystones with siltstones and mudstones), overlain by Quaternary alluvial sediments (gravel soils, sandy loam, loam, clay mixed with organic substances). The roof of bedrock opened at depth of 17,0-22,0 m.

Summarizing all the above the main problems of the reconstruction of the building are:

- construction site is located close to existing buildings with historical value, some of them are in poor technical condition;

- there is need for using of underground space during the reconstruction for more efficient use of the limited space of the construction site;

- presence of the soft soils at the base of the existing building and high water table.

3 NUMERICAL SIMULATION

The purpose of the numerical simulation was to develop design solution that would allow fitting into the existing standards of the Russian Federation. The maximum allowable additional settlements by the existing regulatory literature of RF – 5-10 mm for historical monuments buildings depending on the technical state of buildings *Ponomaryov (2014)*. It is very low value, which is difficult to sustain in the construction of deep underground structures.

Numerical simulations were performed using PLAXIS 2D software package. The calculation was carried out in a flat statement of the problem with the use of Hardening Soil model.

According to the results of numerical simulations were made conclusions about the impossibility of excavation without reinforcement of the foundations of the existing building of Opera Theatre with the use of reinforced jet-grouting piles resting on bedrock represented by sandstones.

Also it is necessary to build a new building with use of pile foundations, supported on low compressibility sandstone. It is impossible to fully improve the ground under the additional part of the theater because it will lead to cut of the existing path of groundwater filtering, and thus cause additional settlements of neighboring buildings.

Examples of the numerical calculated cross sections presented in figure 7.

It was suggested that the construction must be separated to steps. Settlements from the construction of each step in the simulation was summed.

Fencing of excavation ditch will be made from reinforced jet-grouting piles. Depending of excavation depth the fence need to be made from one to two rows of piles. The anchor made with the same technology must be made near existing building of the Opera Theater. To provide the required parameters are sufficient to perform single-row fencing without the anchors in other areas of excavation with a depth less than 3 m.

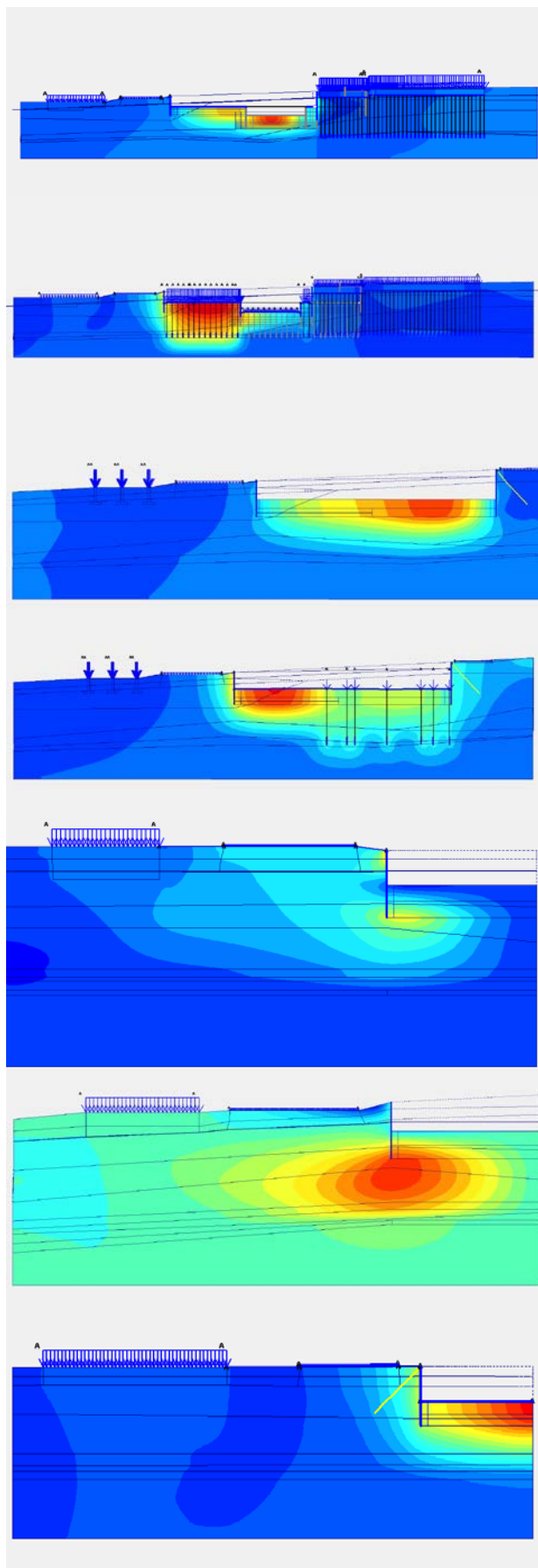

Fig. 7. Examples of the numerical calculated cross sections

The grout curtain with jet-grouting technology is made to prevent water filtration through the bottom of ditch. It is necessary to perform the work from the surface. The thickness of this curtain was chosen for prevention of surfacing by the hydrostatic pressure. Likewise, the grout curtain will be an additional strut for fencing of deep ditch on its bottom. Scheme of proposed fence and grout curtain present on Figure 8.

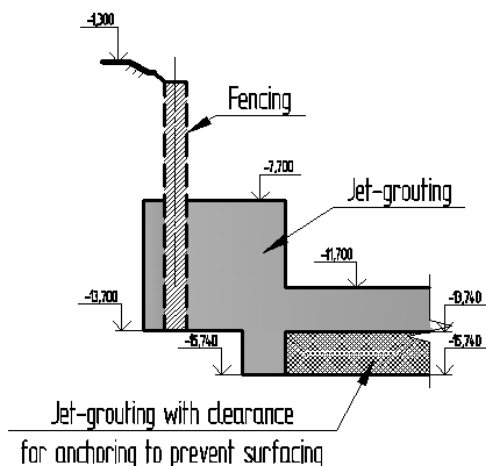

Fig. 8. Scheme of proposed fence and grout curtain

4 CONCLUSIONS

The use of modern software allows to solve complex engineering problems in a variety of settings and to achieve the desired results. With the help of numerical simulation relatively quickly can be sort out the various options of pits and manufacturing operations. However, we must remember that the numerical simulation cannot be the only source of information. In view of this, any complex underground construction in dense urban areas requires a combination of additional work directly related to control of construction site for a confirmation of numerical calculations, as well as to ensure the required level of safety.

Due to the complexity of geotechnical, hydrological conditions of construction, with the aim of guaranteed safety of social objects unique to the city of Perm and the surrounding historic buildings of cultural heritage, the authors offered additional solutions:

- provide scientific and technical support for all the works ranging from exploration to completing the reconstruction;

- as part of the scientific and technical support perform calculations specifying the assessment of the impact of construction on the surrounding buildings, with considerations values of bearing capacity of piles obtained according to field tests;

- before start of the construction (reconstruction) perform full-scale test on the basis of a specially developed project as part of the scientific and technical co-activity;

- carry out geotechnical monitoring during all the reconstruction.

REFERENCES

- 1) Ponomaryov, A.. (2006) Reconstruction of underground space. *Textbook for students studying in the direction 653500 "Building", Moscow, 2006*
- 2) Ponomaryov, A., Kaloshina, S., Bogomolov, A. (2008) Analysis of existing methods of calculation of settlements of buildings and soil stress-strain state. *Bulletin of Volgograd State University of Architecture and Civil Engineering. Series: Construction and architecture. 2008. V. 28. № 9. 4-6*
- 3) Ponomaryov, A., Kaloshina, S., Salimgariev, N. (2013) Influence of processes of flooding on physical and mechanical properties of soils. *Academic Gazette UralNIiproekt RAASN. 2013. № 1. 67-70*
- 4) Ponomaryov, A., Kaloshina, S. (2014) Calculation of settlements of foundation of the existing buildings in case of influence on it of new construction *Proceedings of the higher educational institutions. Building. № 6 (666). 5-13.*
- 5) Kaloshina S. (2007), The most significant factors of construction for buildings in cramped conditions. *Proceedings of the Oryol State Technical University. Series: Construction and Transportation, no. 1-13, RF, 7-10.*
- 6) Kaloshina S., Ponomaryov A.B. (2013) Influence of foundations constructed in dense urban settings on settlements of existing buildings. *Soil mechanics and foundation engineering, no. 5, RF, 194-199.*